





CR40

CE

 Curvatrice idraulica ad elevate prestazioni per profilati metallici e plastici. Corpo macchina in ghisa, ingranaggi in acciaio temperato e tre alberi trascinatori in acciaio, montati su cuscinetti conici e comandati da motoriduttore. La macchina può essere equipaggiata con diverse soluzioni di controllo, per consentire la migliore gestione della geometria da realizzare. L'incremento di curvatura è dato dal movimento dei due alberi laterali, azionati da cilindri idraulici. La macchina è dotata di rulli raddrizzatori laterali indipendenti e predisposta per le eventuali attrezzature complementari. Il pannello di comando, installato su consolle munita di ruote e separata dalla macchina, è alimentato in bassa tensione come da norme vigenti.

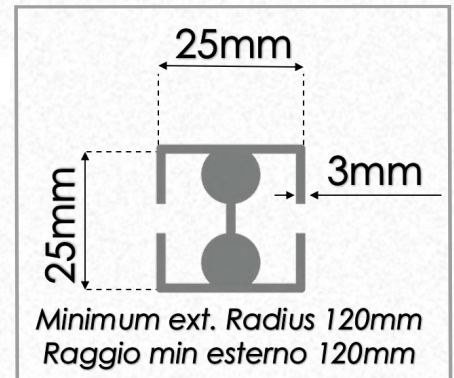
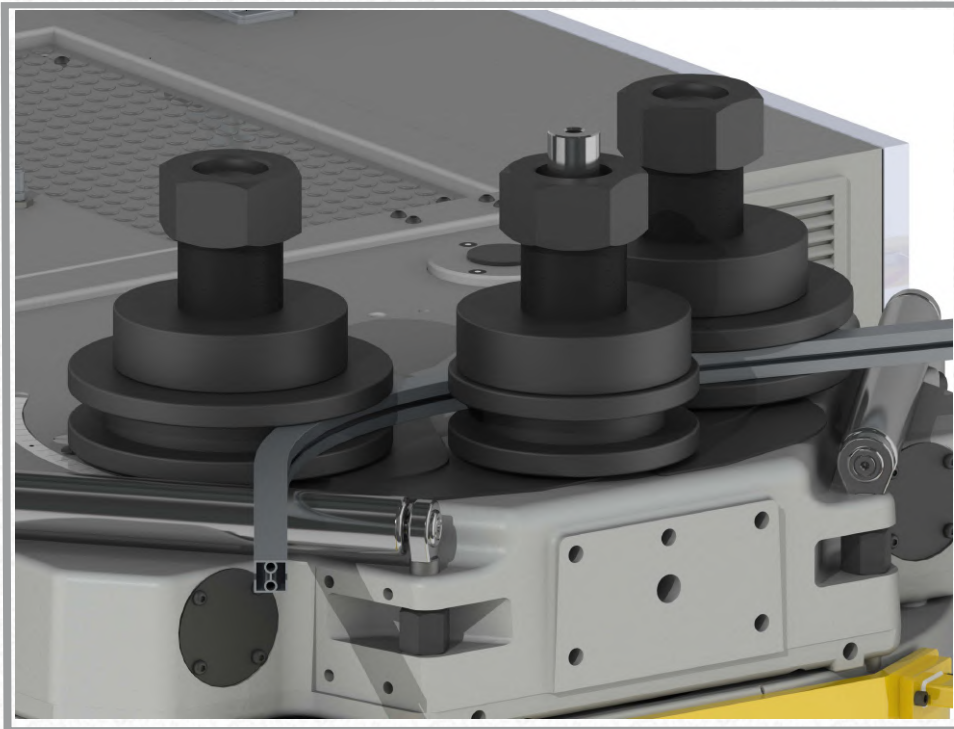
 High performance hydraulic bending machine for metal and plastic profiles. Machine body in cast iron, gears in hardened steel and three steel driving shafts, mounted on conical bearings and controlled by a gearmotor. The machine can be equipped with different control solutions, to allow the best management of the geometry to be made. The increment in curvature is given by the movement of the two lateral shafts, operated by hydraulic cylinders. The machine is equipped with independent lateral straightening rollers and designed for any complementary equipment. The control panel, installed on a wheeled console separate from the machine, is powered by low voltage as per the regulations in force.



 Cintreuse hydraulique très performante de haute précision pour profilés métalliques et plastiques. Corps de la machine en fonte, engrenages en acier trempé et trois axes d'entraînement en acier, montés sur des roulements coniques et commandés par motoréducteur. La machine peut être équipée de différents types de contrôle, pour permettre une meilleure gestion de la géométrie à réaliser. L'incrémentation pour le cintrage est réalisée par l'avancement hydraulique des deux axes latéraux. La machine est équipée de rouleaux redresseurs latéraux indépendants et prédisposée pour les éventuels équipements complémentaires. Le pupitre de commande, indépendant sur roulettes, est alimenté en basse tension, conformément aux normes en vigueur.

 Curvadora hidráulica de alto rendimiento para perfiles metálicos y plásticos. Cuerpo de máquina de fundición, engranajes de acero templado y tres ejes motrices de acero, montados sobre cojinetes cónicos y controlados por motorreductor. La máquina se puede equipar con diferentes soluciones de control, para permitir la mejor gestión de la geometría a realizar. El incremento del curvado se obtiene mediante el avance hidráulico de los dos ejes laterales. La máquina está equipada de rodillos rectificadores laterales independientes y preparada para los eventuales equipos complementarios. El panel de control, instalado en la consola equipada con ruedas y separado de la máquina, está alimentado en baja tensión según las normas en vigor.



Hydraulische Biegemaschine mit erhöhten Leistungen für Metall- und Kunststoffprofile. Maschinenkörper aus Gusseisen, Zahnräder aus gehärtetem Stahl und drei auf konische Lager montierte Mitnehmerwellen aus Stahl, die von einem Motoruntersetzungsgetriebe gesteuert werden. Die Maschine kann mit verschiedenen Steuerungen ausgestattet werden, um die bestmögliche Verwaltung der zu erstellenden Geometrie zu ermöglichen.

Die Bogensteigerung erfolgt durch den Vorschub der beiden seitlichen Walzen, die von hydraulischen Zylindern angetrieben werden. Die Maschine ist mit unabhängigen seitlichen Gleichrichterwalzen ausgestattet und für die Montage komplementärer Geräte und Ausrüstungen vorbereitet.

Das Bedienfeld wird gemäß den geltenden Vorschriften mit Niederspannung betrieben und auf ein von der Maschine getrenntes und mit Rädern versehenes Pult montiert.

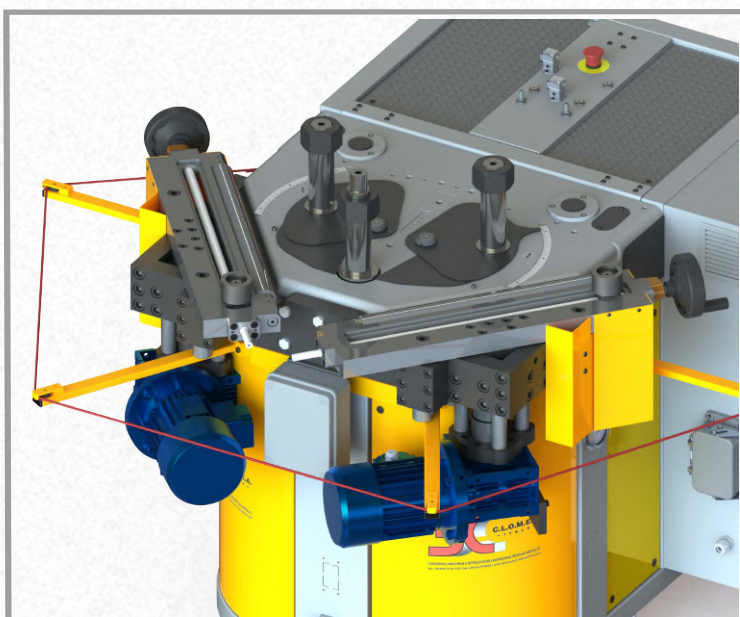
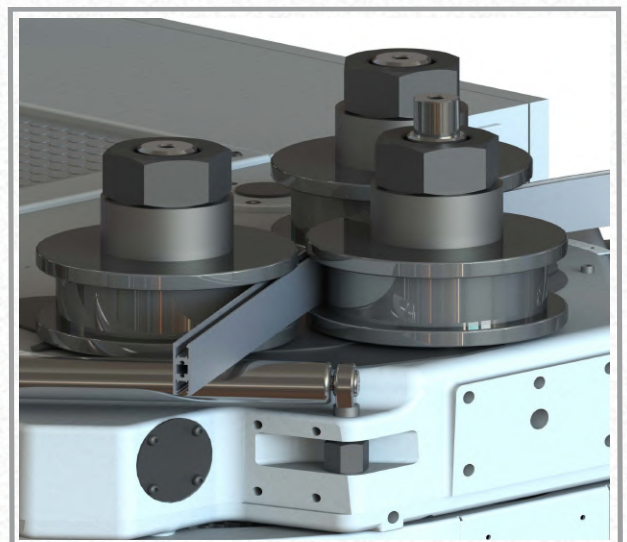



IT Kit attrezzatura rulli raddrizzatori elettromeccanici ad azionamento manuale visualizzato, con movimento su 2 assi anche contemporaneo con il rullo curvatore.

GB Kit of manually operated electromechanical straightening rollers with displayed operation and movement on 2 axes also simultaneous with the bending roller.

F Kit d'équipement de rouleaux redresseurs électromécaniques à commande manuelle visualisé, avec mouvement sur 2 axes même simultané avec le rouleau de cintrage.

ES Dispositivo rodillo enderezador electromecánico de accionamiento manual visualizado con movimiento a 2 ejes incluso simultáneo con el rodillo curvador.

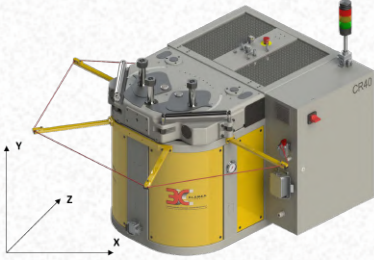
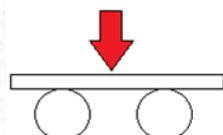
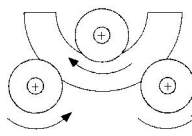
D Elektromechanischer Richtrollen-Ausstattungsatz mit angezeigter manuell bedienter Bewegung auf 2 Achsen auch gleichzeitig mit der Biegewalze.

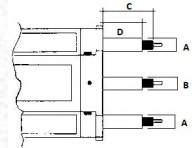
	<p>CR 40</p> <p>X mm 1100</p> <p>Z mm 1300</p> <p>Y (h) mm 1200</p>	 	<p>BENDING FORCE = 11 t</p> <p>W max (cm³) = 8</p> <p><u>ROTATION SPEED</u></p> <p>CR40CN33 / 23 / 12 = rpm 1 - 15,6 (IM)</p> <p>CR40CN33 / 23 / 12 = rpm 4,9 - 9,8</p> <p>CR40CN11 / 09 = rpm 9,8</p>
	<p>WEIGHT kg 530</p>		
	<p>A= Ø mm 40</p> <p>B= Ø mm 40</p> <p>C= mm 145</p> <p>D= mm 110</p>		

ACCESSORI IN DOTAZIONE

Tanica di sabbia - Chiavi di servizio - Pistola di soffiaggio aria compressa

ACCESSORIES INCLUDED

Sand can - Service wrenches - Air blow gun

ACCESSOIRES INCLUS

Recipient de sable spéciale - Clés de service - Soufflette

ACCESORIOS INCLUIDOS

Contenedor de arena - Llaves de servicio - Pistola de soplado

MITGELIEFERTES ZUBEHÖR

Sandbehälter - Serviceschlüssel - Druckluftpistole zum Ausblasen

ACCESSORI A RICHIESTA

Rulli a disegno - Archimetro - Rulliere - Attrezzature complementari

OPTIONAL

Rollers upon drawing - Arc meter - Support benches - Complementary equipment

DOTATION SUR DEMANDE



















Galets acier/nylon - Archimetre - Tables de support - Equipements complementaires

DOTACIÓN SOBRE DEMANDA

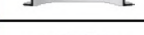
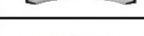
Rodillos a dibujo - Medidor de arco - Mesas de apoyo - Equipos complementarios

AUF ANFRAGE

Walzen nach Zeichnung - Biegeradiusvermessungsgerät - Rollgänge - Ergänzungsausrüstungen

MATERIALE / MATERIAL			Fe 430 / S275
1	Piatto di costa Flat Hard		mm 60x10
2	Piatto di piatto Flat Easy		mm 100x15
3	Quadro Pieno Square Bar		mm 30
4	Tubo Quadro Square Tube		mm 50x2,5
5	Tubo Rettangolare Rect. Tube, Hard		mm 60x30x3
6	Tubo Rettangolare Rect. Tube, Easy		mm 70x30x3
7	Tondo Pieno Round Bar		mm Ø35
8	Tubo Tondo Round Tube		mm Ø60x3
9	Tubo API Api Pipes		Ø 1 1/2"
10	T Ala Tirata Tee Leg-out		mm 60x7
11	T Ala Compressa Tee Leg-in		mm 50x6
12	T Ala in Piano Tee Leg Easy		mm 70x5
13	C Ali Tirate C Leg-out		mm 70x40x6
14	C Ali Comprese C Leg-in		mm 60x30x6
15	C di Costa C Hard Way		mm 50x25x5
16	Angolare Ala Tirata Angle Leg-out		mm 60x5
17	Angol. Ala Compressa Angle Leg-in		mm 50x6
18	Travi IPE di Piatto I-Beam Easy Way		mm 80x46
19	Travi IPE di Costa I-Beam Hard Way		
20	Travi HEA di Piatto H-Beam Easy Way		
21	Travi HEA di costa H-Beam Hard Way	